

ultraframe



Window & Door Products

Orangery Products

Home Extension Products

Conservatory Products

Skylight Products

Classic Low Pitch Lean-to

Technical Guide
Version 2 | Jan 2012

This system allows roof fitment down to 2.5° degrees. Featuring the use of ready made firrings or your own raked frames, it allows fitment of a lean-to conservatory to even the most awkward bungalow situation.



Features & Benefits

- Available in two polycarbonate glazing options
- 25 and 35mm or unglazed for 4-16-4 units
- Fully variable pitch (2.5° to 10°)
- 3 colour options – White, Rosewood and Light Oak (internal and external)
- Structural firrings at 2.5° and 5° are available in the 3 colour options
- Suitable for raked frames too
- Tested and approved by the BBA down to 2.5° degrees
- Integrated wall plate ventilation system for additional comfort
- Optional box gutter allows 'work arounds' on restricted soffit situations

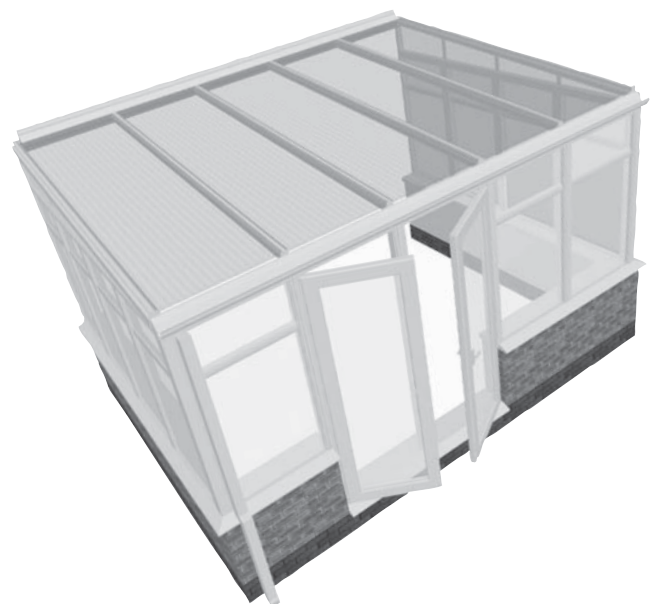



For help and guidance with detailing or specification please contact our technical support team on:-
Tel: 0843 208 6953 Fax: 0843 208 6952 Email: techsupport@ultraframe.co.uk

Eaves assembly

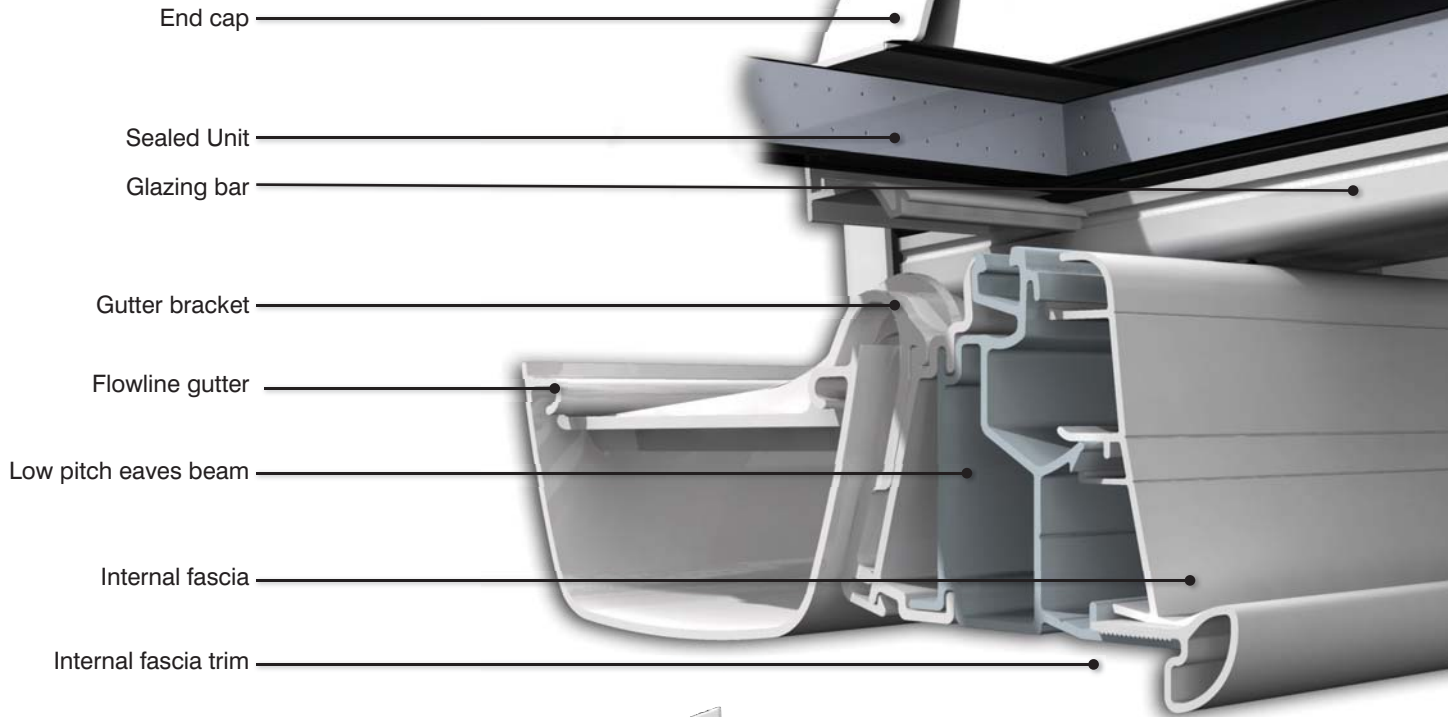

Wall plate assembly

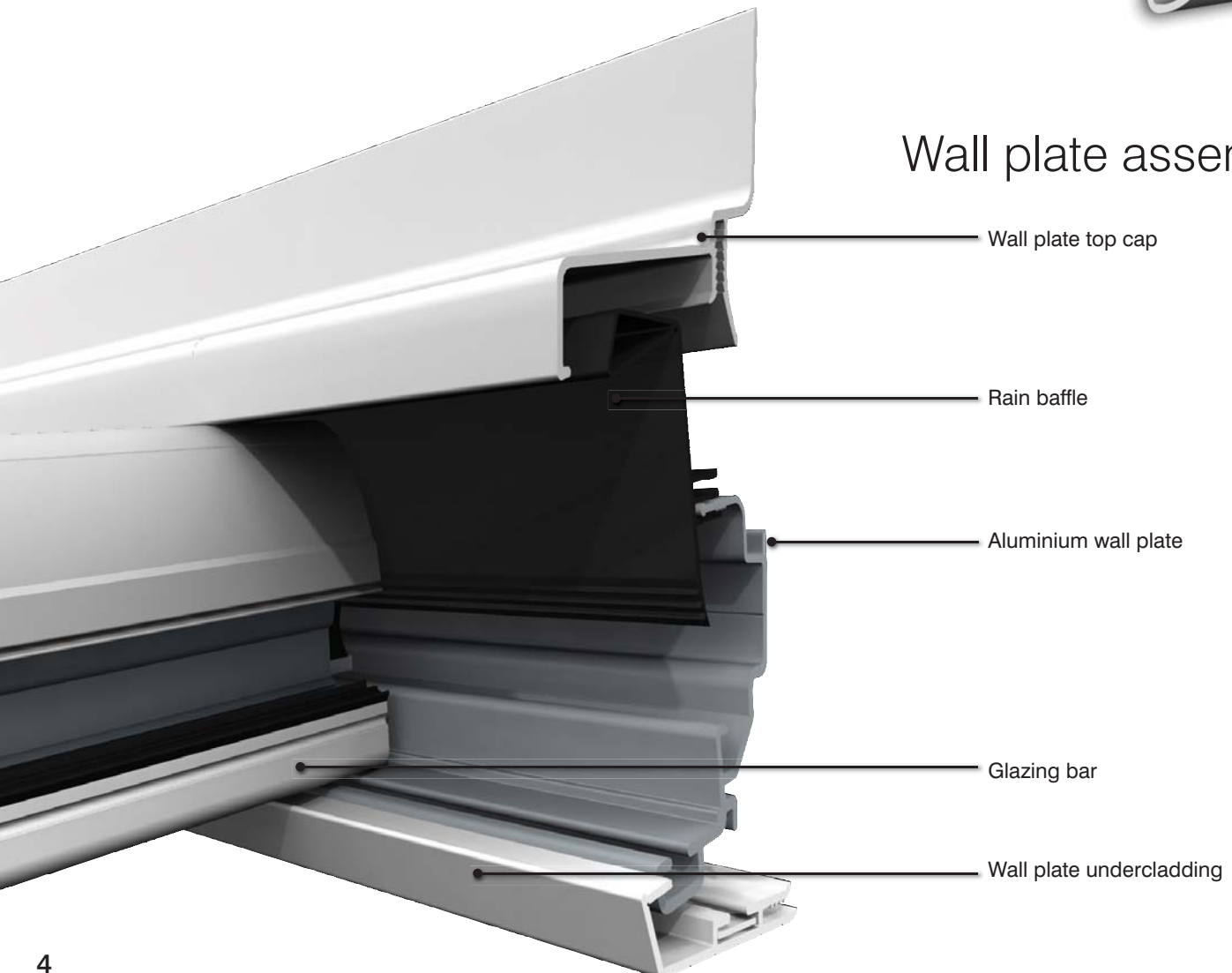

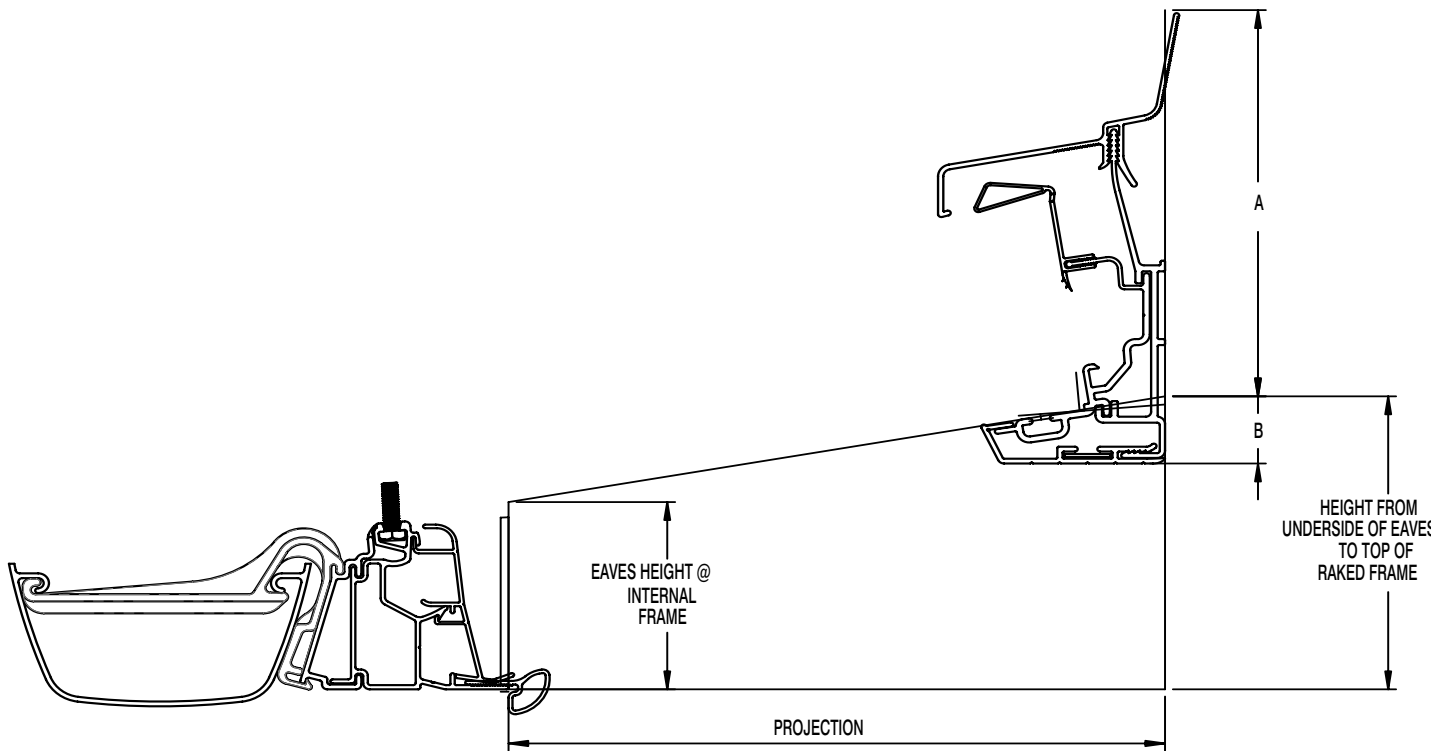

VENTILATED WALL PLATE HEIGHT RESTRICTION DETAILS

PITCH (°)	2.5°	3°	3.5°	4°	4.5°	5°	5.5°	6°	6.5°	7°	7.5°	8°	8.5°	9°	9.5°	10°
DIM A (mm)	166	165	165	165	165	164	164	164	163	163	163	163	162	162	162	161
DIM B (mm)	23	24	24	24	24	25	25	25	26	26	26	26	27	27	27	28

HEIGHT FROM UNDERSIDE OF EAVES TO TOP OF RAKED FRAME AT WALL

PITCH	EAVES HEIGHT AT INTERNAL FRAME (mm)	PROJECTION (mm)															
		2500	2600	2700	2800	2900	3000	3100	3200	3300	3400	3500	3600	3700	3800	3900	4000
2.5°	72	181	185	190	194	198	203	207	212	216	220	225	229	233	238	242	247
3°	72	203	209	214	219	224	229	235	240	245	250	256	261	266	271	277	282
3.5°	73	226	232	238	244	250	256	262	268	274	281	287	293	299	305	311	317
4°	73	248	255	262	269	276	283	290	297	304	311	318	325	332	339	346	353
4.5°	74	270	278	286	294	302	309	317	325	333	341	349	357	365	372	380	388
5°	74	292	301	310	319	327	336	345	354	362	371	380	389	397	406	415	424
5.5°	74	315	324	334	344	353	363	373	382	392	402	411	421	430	440	450	459
6°	75	337	348	358	369	379	390	400	411	421	432	442	453	463	474	484	495
6.5°	75	360	371	383	394	405	417	428	439	451	462	474	485	496	508	519	531
7°	76	382	395	407	419	431	444	456	468	480	493	505	517	530	542	554	566
7.5°	76	405	418	431	444	457	471	484	497	510	523	536	550	563	576	589	602
8°	76	427	441	456	470	484	498	512	526	540	554	568	582	596	610	624	638
8.5°	77	450	465	480	495	510	525	540	555	570	585	600	614	629	644	659	674
9°	77	473	489	504	520	536	552	568	584	599	615	631	647	663	679	695	710
9.5°	78	496	512	529	546	562	579	596	613	629	646	663	680	696	713	730	747
10°	78	518	536	554	571	589	607	624	642	659	677	695	712	730	748	765	783

Section 5

FIRRING SPECIFICATION

- Available at 2.5° and 5° pitch in 3045mm and 4045mm lengths - these need to be cut to length on site.*
- The firrings consist of a series of inter connected/locking profiles that are supplied pre-fabricated.
- Firrings are supplied in 3 different 'conditions' to suit various projections and applications (see table below).
- When specifying only one firring, it must be confirmed whether this is the left or right hand (as viewed externally from front of conservatory).
- The guttering can be clipped to the firring allowing the guttering to run along the front and sides of the conservatory. This can save the need for a soakaway as the guttering can be routed back to the house and rain water dispersed down the dwelling's existing fall pipes.

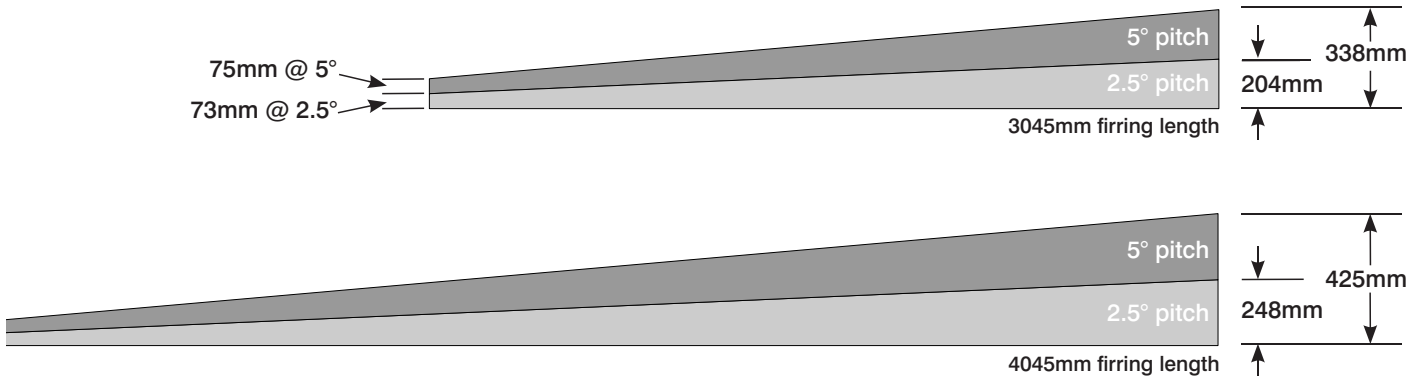

Recommended firring specification rules:

Ultraframe have gone one step further with these ready assembled interlocking profiles that not only fill the 'hole' between the side frames and the roof but which add substantial support to the whole structure particularly when doors are in the end elevations.

Performance based on Standard Load - Snow 0.6kN/m²

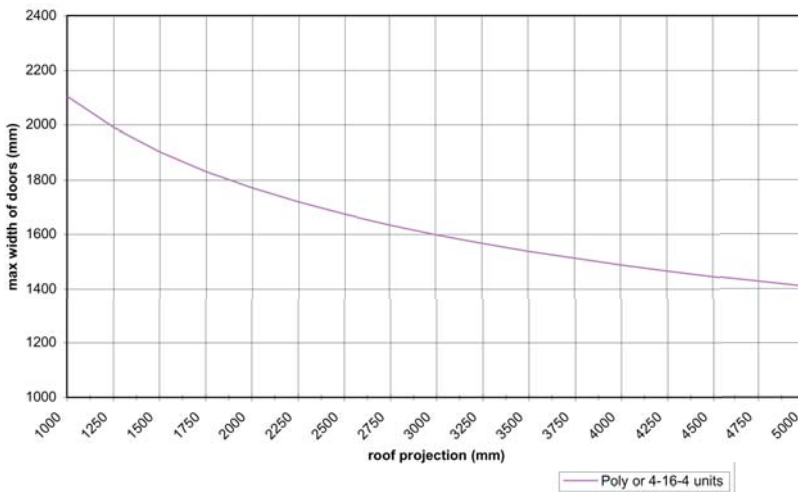

25/35mm Polycarbonate	Standard	Stage 1 Reinforcement (Aluminium)	Stage 2 Reinforcement (Aluminium & Steel)
up to 3000mm projection			
without doors	■	□	□
with doors	X	■	□
over 3000mm and up to 4000mm (maximum firring length)			
without doors	X	■	□
with doors	X	X	■

■ Recommended □ Optional X Not suitable

When doors are in either the sides or the front of the conservatory, the door outer frame profile must be reinforced

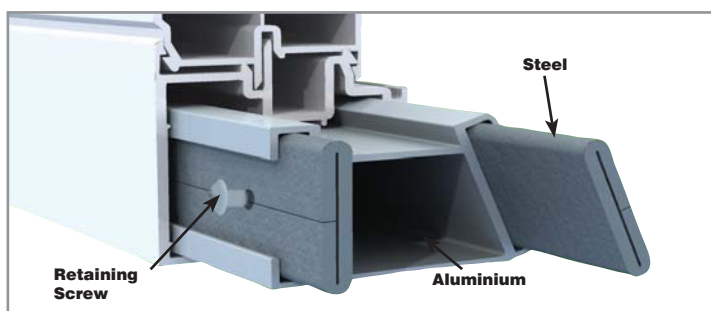

*When firrings are supplied with stage 2 steel reinforcement and are cut to length on site, it is essential that the retaining screws are refitted if removed (see left) Failure to do so may result in the steel moving or rattling when doors underneath are opened/closed.

When there is insufficient height, under the bungalow soffit it may necessary to utilise a box gutter with an extended leg and flange to gain extra height.

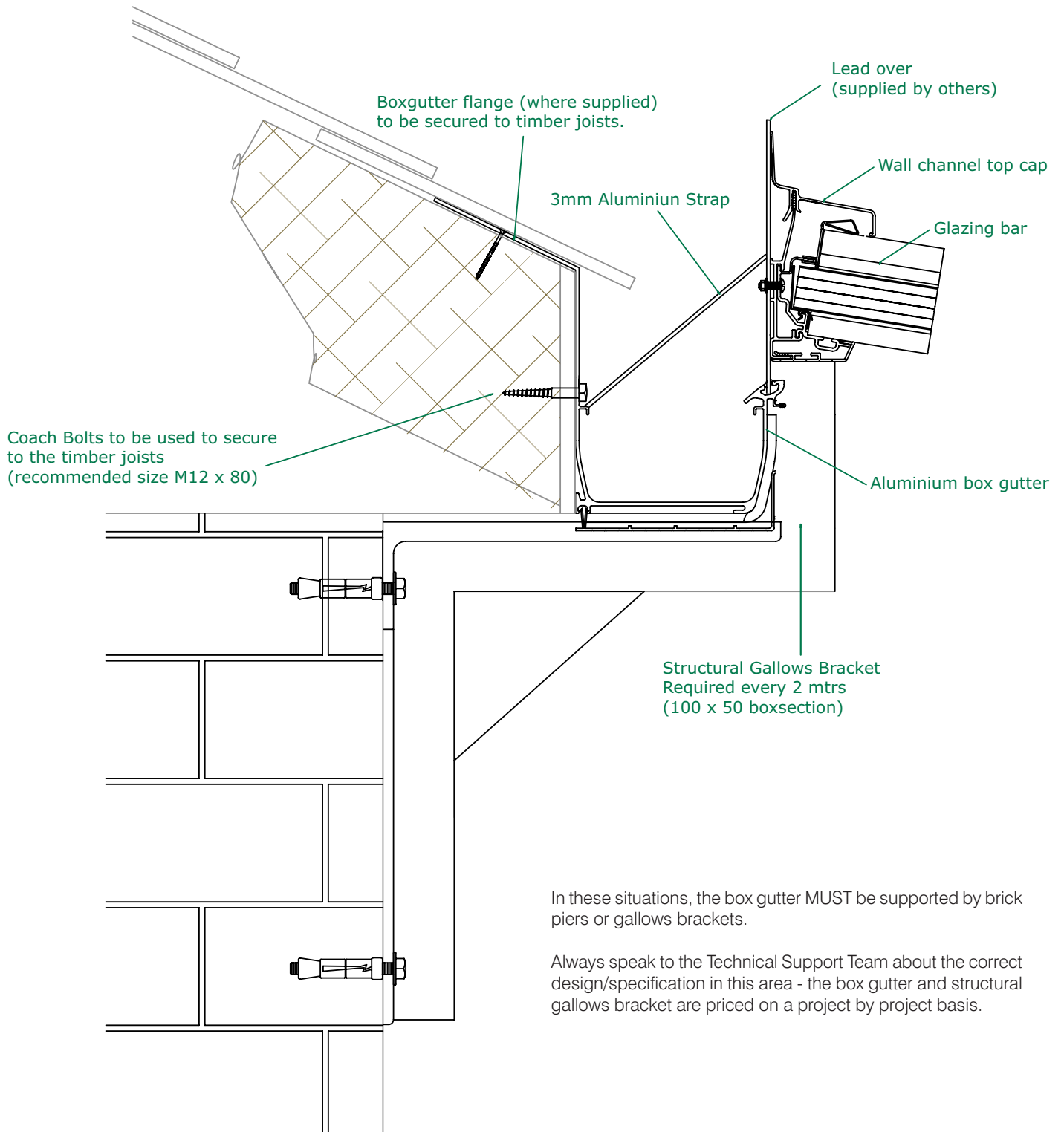

ultraframe

Transforming light and space

www.ultraframe.co.uk

Ultraframe (UK) Ltd, Salthill Road, Clitheroe, Lancashire. BB7 1PE