

sapa:

Architectural **Aluminium** Solutions



Elegance 52 & Elegance 72

Curtain Walling & Facade Systems

Sapa Building System

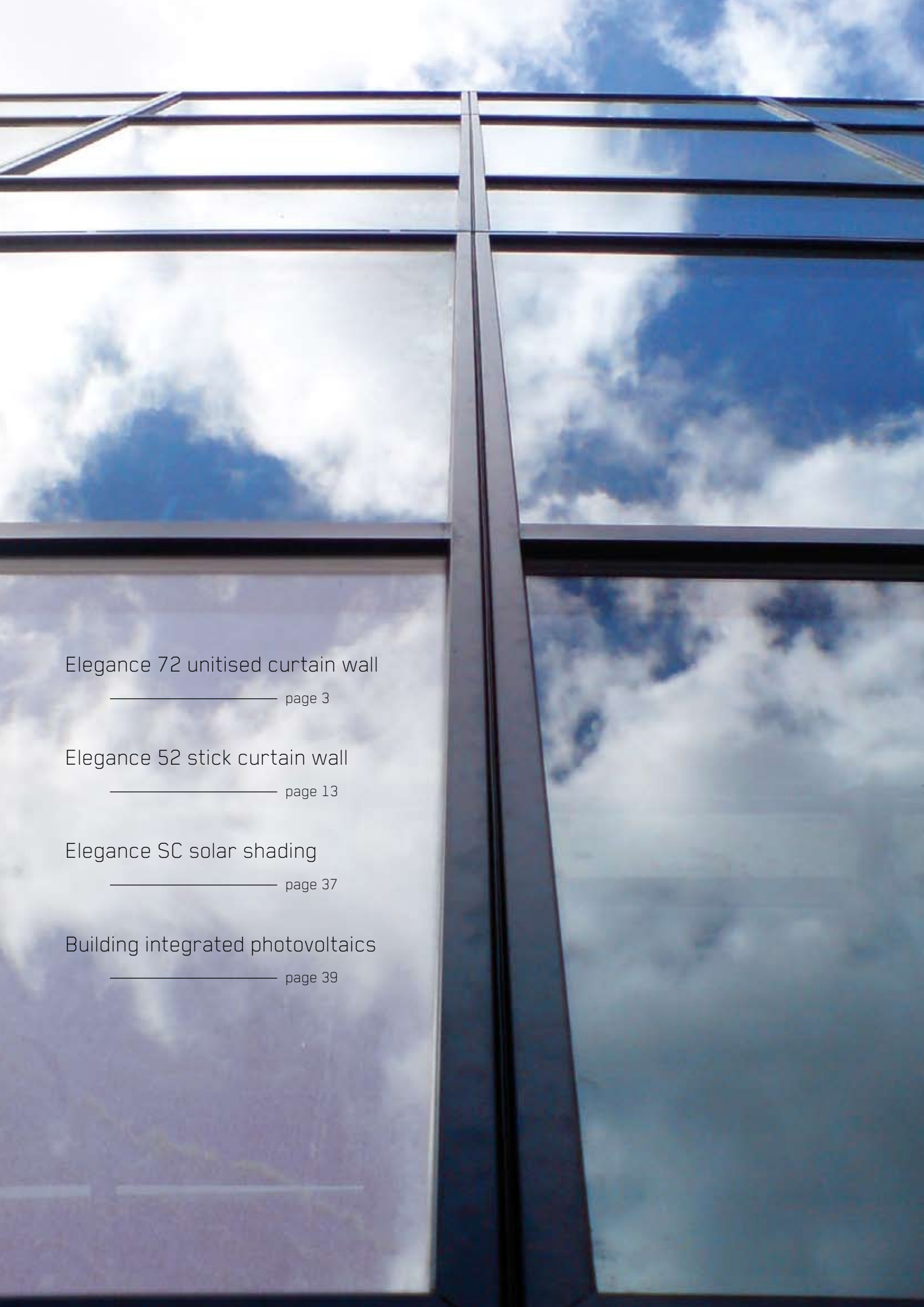

Elegance 72 unitised curtain wall

————— page 3

Elegance 52 stick curtain wall

————— page 13

Elegance SC solar shading

————— page 37

Building integrated photovoltaics

————— page 39

Elegance 72 is a unitised curtain walling system that brings together the benefits of factory production control and speed of installation on site. Modular units are manufactured including glazed units in workshop conditions, where quality can be strictly controlled. The fixing lugs are built into the perimeter, ensuring ease of handling during transportation and arrival on site.

Fitting the modular panels into place takes far less time than constructing a traditional stick-build system and, for installations where scaffolding is unavailable or impractical, cranes can be used to hoist the panels into position quickly, efficiently and above all safely

Elegance 72 can incorporate windows and doors from the Sapa Building System range, as well as Elegance SC Solar Control and solar power generation through our Building Integrated Photovoltaic system, thus providing a complete façade solution for any building type or style.



Production

- › Modular units are manufactured including glazing units in the factory. This ensures an optimized:
 - Production process
 - Labor cost
 - Maximal control on quality
 - No influence of the weather.
- › Fast glazing without screwing by using the different external glazing beads.

Installation

- › Frames are fitted one floor level at a time
- › The units are craned or winched into position and secured from the inside of the building, reducing costs and encouraging safer working conditions
- › Dry connections between dilatation gasket for water tightness up to 1500 Pa.
- › The storage of cladding materials and glass handling on site can be completely eliminated - a major advantage for constrained city centre sites
- › Significantly improved quality and performance because the façade panels are completed off-site in a controlled factory environment.

Weather performances

- › The Elegance 72 is able to accept tolerances and movements caused by thermal expansion, without compromising the weather performance. The variable width of dilatation is horizontal 14 mm and vertical 10 mm.
- › Zone drainage, where each pane acts as an individual self draining unit.
- › Fully drained and pressure equalized for optimal weather performance.
- › The international test institute had never gone to 1500 Pa on a static water test before.
- › Weather resistance: A4 (EN 12152); R1500 (EN 12154); 2400 Pa (EN 13116)

Off site manufacturing

Sealing gaskets: two levels of gaskets run continuously along the top of the frame.



Lifting & Lining plates: Fitted to top corner of frame to allow for lifting during transport and installation.



On site speed and safety

Installation: frames are fitted one floor level at a time.





Cost Effective

- » There are cost savings on site preliminaries and scaffolding
- » The option of standardisation for economies of scale and material optimisation
- » Faster programme times leading to earlier occupation and a faster return on investment for the developer
- » Construction is less affected by inclement weather
- » More efficient control of materials, including less wastage, loss and damage
- » The façade panels are manufactured off-site and craned into position, making this a highly efficient solution where site access is restricted.

Freedom in design

- » A wide range of decorative cover caps (bull nose, rectangular, airofoil, etc) gives the freedom to design visually interesting glazing
- » By combining different cover caps for horizontal and vertical applications, a wide diversity of external features is possible
- » Several designer mullions are available for internal design features
- » Mullions and transoms can be flush at the inside or can be specifically different to emphasis the vertical design complementing the total building design
- » Several situations such as 90° angle mullions or variable angles have been designed with a minimal use of material, allowing slim sightlines
- » By using the various designer mullions/transoms possibilities, in combination with the extensive colour range, the different options are practically unlimited.
- » Suitable for both new build and refurbishment.
- » Elegance 72 is compatible with Elegance 52, all profiles of Elegance 52 can be used as internal mullions and transoms.
- » The system is available in structurally glazed aluminium and structurally clamped aluminium. Horizontal or vertical lining are also part of the offer.



Custom made

- » For every project the SBS expert team can optimize the building blocks in order to have the most efficient solution. The well proven core of the E72 system will be the base for all possible design and technical requirements

Project support

- » Sapa Building System's experienced project Team will advise you on the best product solutions
- » We can help you with pricing, strength calculations, building connections, thermal simulations, etc
- » Specific project solutions can be developed
- » Samples, catalogues, technical specifications and digital drawings are available.





Energy

- » Elegance 72 offers the highest standard of thermal insulation thanks to the combination of the 28 or 36 mm polyamide strips and the specially developed gaskets as shown in detail.
- » Elegance 72 can accept glass and panels depths from 6 to 50 mm.
- » The high thermal performance level improves the overall building insulation, leading to a lower total energy consumption, thereby helping our environment.

Finishes

- » A wide range of polyester powder coated finishes is available to BS EN 12206:2004.
- » Anodised finishes are also available to BS3987.
- » Accessories can be supplied in corresponding colours to match the profiles
- » It is possible to have dual-colour finishes, so that the external finish does not dictate the internal colour



Environment

- » All Sapa Building Systems profiles are easily cleaned
- » Aluminium does not rust, rot or tear and the shape does not deform
- » Aluminium is a green product, which can be recycled infinitely without quality loss

Testing

- » In order to ensure confidence amongst specifiers and contractors, Sapa Building System has carried out a full test procedure to EN and CWCT Standards.
- » The static water test results were the highest seen by Taylor Woodrow Engineering, at 1500Pa.







Applications

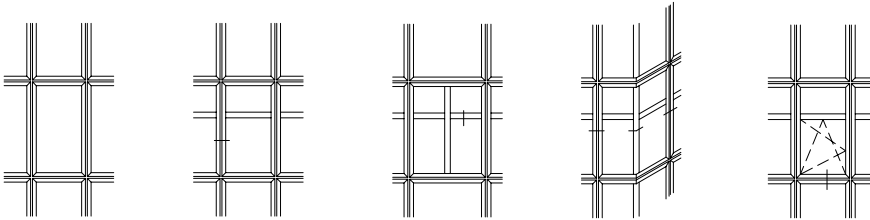

Dimensions

| | |
|---------------------------------------|--|
| Min. sightline | 72 mm |
| Min. sightline transom | 52 / 72 mm |
| Min. sightline inward opening window | 161 mm |
| Min. sightline outward opening window | 130 mm |
| Profile depth element | 85 - 177 mm (adaptable to project requirements) |
| Max. size element (width x height) | 1500 x 4000 mm (adaptable to project requirements) |

Glazing

| | |
|------------------------------|---|
| Rebate height | 21 mm |
| Infill thickness 36 mm strip | 6 - 50 mm |
| Infill thickness 28 mm strip | 6 - 38 mm |
| Glazing method | dry glazed with EPDM gaskets or silicon |

Performances*

| | | |
|--------------------------------|---|-----------------------|
| Thermal insulation | $2,3 \text{ W/m}^2\text{K} \leq U_t \leq 3,1 \text{ W/m}^2\text{K}$ | EN ISO 10077-2 |
| | $2,4 \text{ W/m}^2\text{K} \leq U_m \leq 3,4 \text{ W/m}^2\text{K}$ | EN ISO 10077-2 |
| Air permeability | A4 / 600Pa | EN12152 / CWCT Seq. B |
| Water tightness | RE1500 / 600Pa | EN12154 / CWCT Seq. B |
| Wind resistance, security test | 2400Pa / 2400Pa | EN13116 / CWCT Seq. B |
| Impact resist | E5 | EN 14019 |

This information is an indication of potential performance with specific components. For more information, please consult Sapa Building System Ltd.

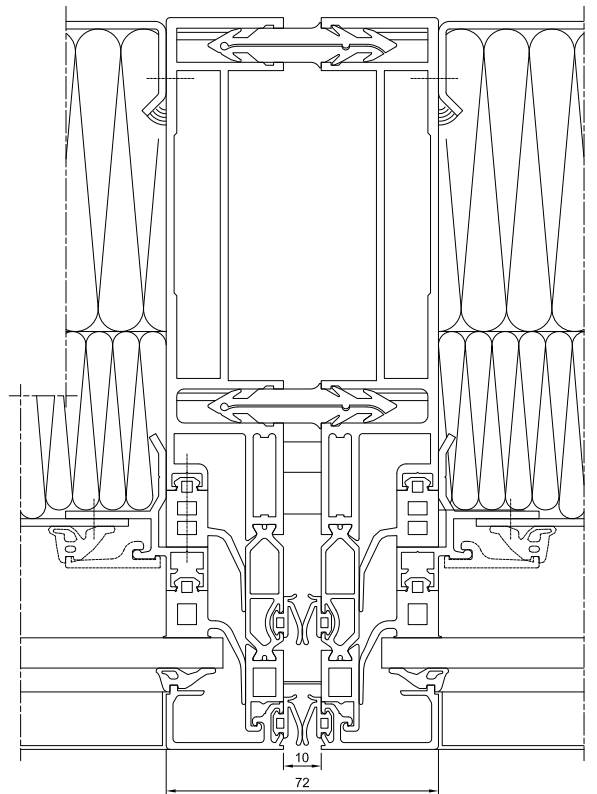
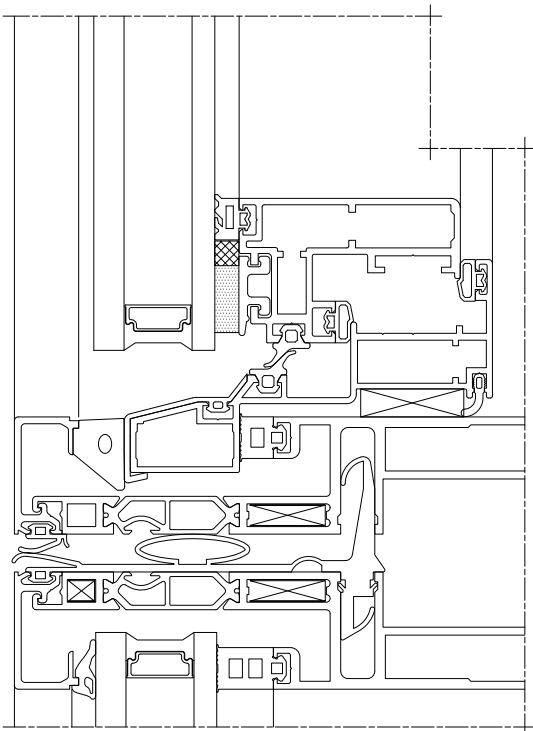
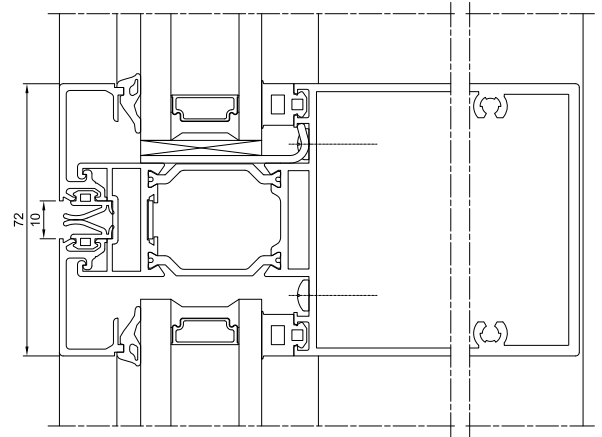
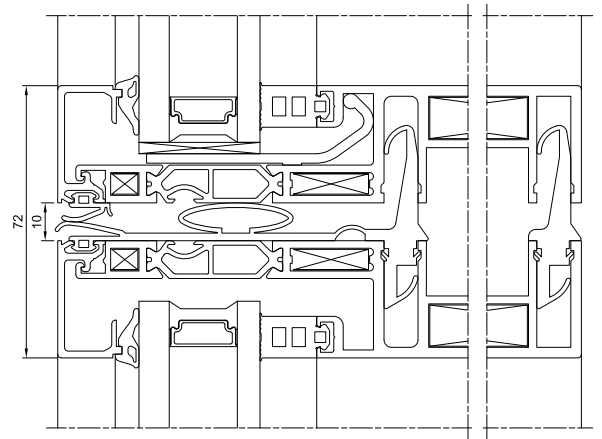
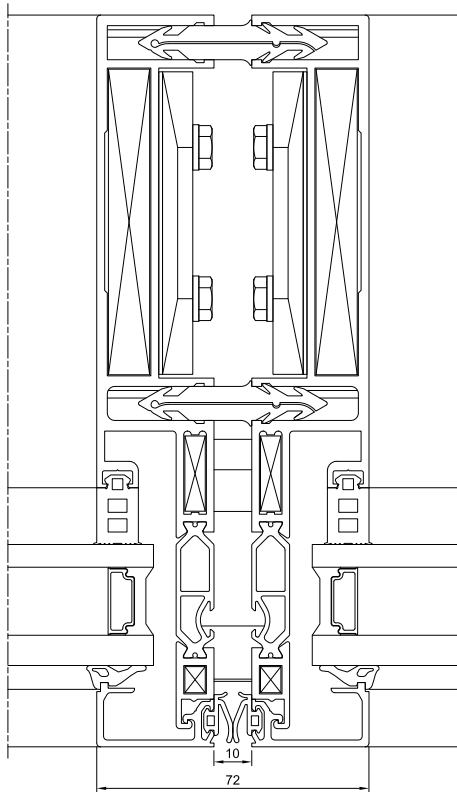

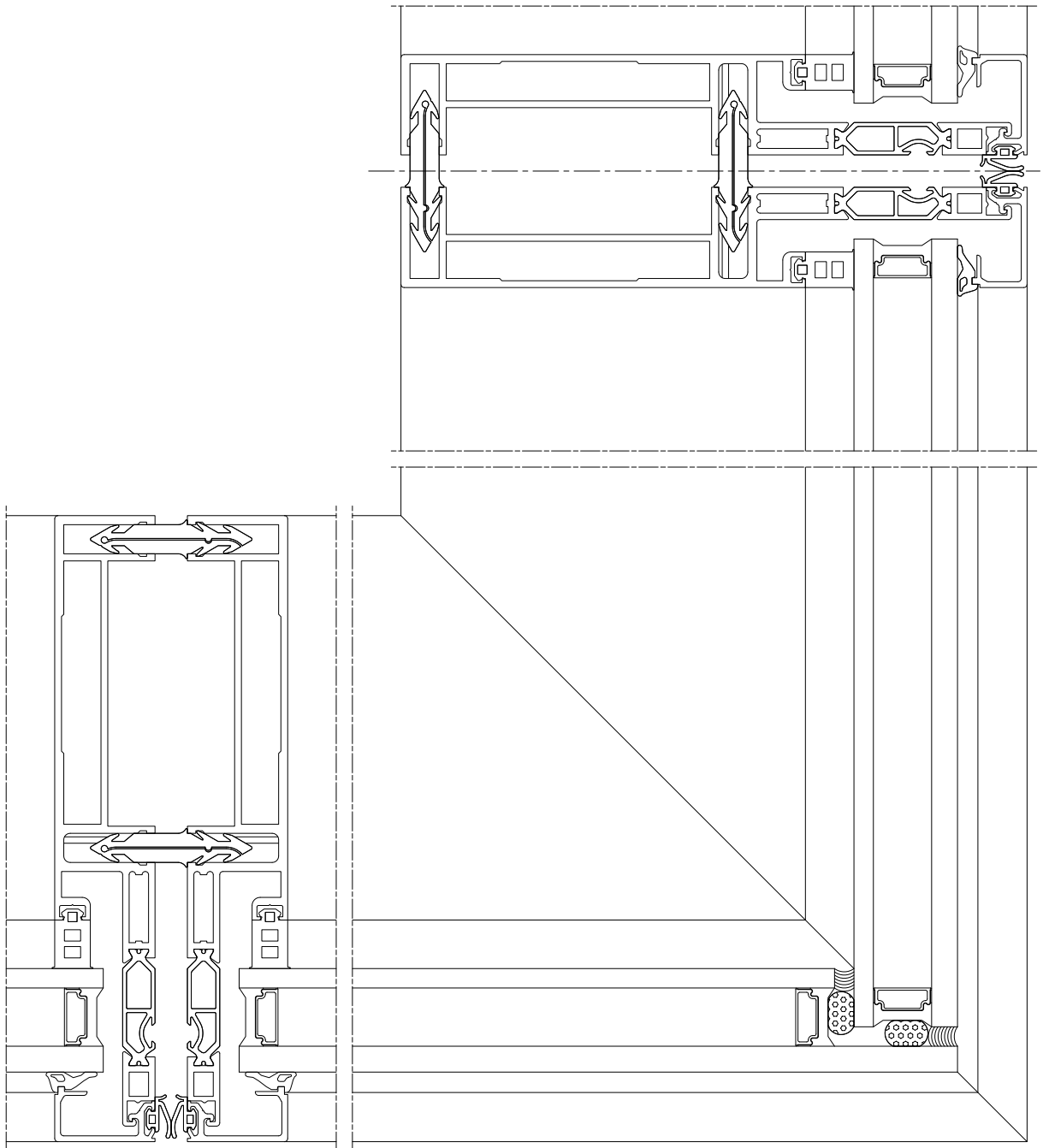



Elegance 52 is a comprehensive curtain wall system that combines technology and design with the demands of contemporary building design and construction. All Elegance 52 systems use a common substructure with a width of 52 mm, allowing a slim sightline, whilst maintaining the necessary strength and inertia requirements for most applications.



Weather performance, thermal insulation, building connection, ease of fabrication and installation were the key factors that influenced the design of Elegance 52.

Extensive range of solutions

All Elegance 52 applications are made up from a set of durable mullions and transoms with a profile width of 52 mm. A large range of profiles depths is available to suit the structural requirements and to give the most economical solution.

- » Elegance 52 is available in different versions, each providing unique design features:
 - Elegance 52 ST (standard)
 - Elegance 52 HL (horizontal lining)*
 - Elegance 52 SG Vent (frameless window)*
 - Elegance 52 IN (industrial look)*
 - Elegance 52 FR (fire resistant)*
 - Elegance 52 Burglary resistant (class 2)*
 - Elegance 52 SX (structurally clamped)*
 - Elegance 52 SG (structural glazing)*
 - Elegance 52 GF (glazed frame)*
 - Elegance 72 (unitised curtain wall)*
 - Elegance SC (Solar Control)*
 - Building Intergrated Photovoltaic*
- * Versions denoted thus are available on a project specific basis only. Minimum quantities and extended lead times may apply. Please consult Sapa Building System prior to specifying or ordering.
- » Elegance 52 can be used in vertical, sloped or roof applications, it offers several solutions for connections to other levels of curtain walling and building materials, whilst always allowing maximum weather performance and minimal sightlines.
- » Elegance 52 system provides integration with existing window and door systems of the Sapa Building System product range.

Fabrication and Installation

- » Drainage can be both field / compartmental or mullion drained.
- » Specially developed aluminium profiles or steel can be inserted in the mullions to assure a higher inertia for extremely large spans and to provide a continuous mullion connection and anchorage.
- » System of dry glazing by means of EPDM gaskets.
- » All window and door systems of the Sapa Building System product range have accessories specifically designed to allow easy integration in the curtain wall.
- » Depending on the type of application the system can be mullion-mullion or mullion-transom connected. Front mounting of transoms is made possible by spring cleats. A mullion-cut out solution was developed for situations when extra support for the transoms is required.
- » Punch tools specifically designed for the Elegance 52 ensure accurate and fast prefabrication of drainage holes and transom cut outs.

Elegance 52 ST is a standard thermally broken curtain wall system that offers many design options by the use of different designer mullions and cover caps. Elegance 52 ST offers solutions for vertical, slope and roof applications and can solve faceted curtain wall requests.

System features

- » Elegance 52 ST can accept glass and panels depths of 4 to 50 mm.
- » The system can be self-supporting or can be used in combination with a supporting structure.
- » Elegance 52 ST is able to accept tolerances and movements caused by thermal expansion, without compromising the weather performance.
- » Weather resistance: AE 750 (EN 12152); RE 750 (EN 12154); 3000 Pa (EN 13116)

Elegance 52 ST

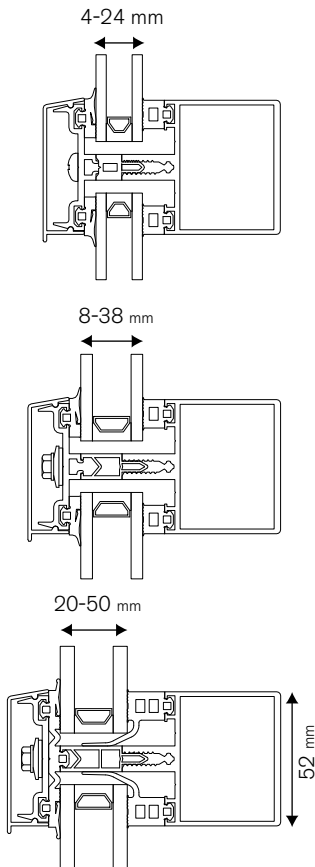

Dimensions

| | |
|----------------------|-------------------------------|
| Sightline | 52 mm |
| Mullion depth | 41 - 273 mm |
| inertia (lxx: wind) | 9,57 - 1649,7 cm ⁴ |
| Transom depth | 22,5 - 199 mm |
| inertia (lxx: wind) | 3,67 - 515,84 cm ⁴ |
| inertia (lyy: glass) | 1,09 - 53,03 cm ⁴ |

Glazing

| | |
|------------------|------------------------------|
| Infill thickness | 4 - 50 mm |
| Glazing method | dry glazed with EPDM gaskets |

Performance

| | | |
|-----------------------|---|----------------------|
| Thermal break | 4 - 36 mm | |
| Thermal insulation | $U_{cw} < 1,4 \text{ W/m}^2\text{K}$ with glass $U_g = 1,2 \text{ W/m}^2\text{K}$ | EN ISO 10077-2 |
| Air permeability | AE750 / 600Pa | EN12152 / CWCT Seq B |
| Water tightness | RE750 / 600Pa | EN12154 / CWCT Seq B |
| Wind Resistance | 3000Pa / 2400Pa | EN13116 / CWCT Seq B |
| Acoustics: | | |
| with glass 6/15/4 | $R_w(C;C_{tr}) = 34(0;-2)\text{dB}$ | |
| with glass 10/15/6 | $R_w(C;C_{tr}) = 36(-1;-2)\text{dB}$ | |
| with glass 12/16/44.2 | $R_w(C;C_{tr}) = 42(-2;-5)\text{dB}$ | |
| Impact test | class 5 | EN14019 |

This information is only an indication of potential performance with specific components. For more information, please consult Sapa Building System Ltd.



Design

- » A wide range of decorative cover caps (bull nose, rectangular, aerofoil, etc) gives the freedom to design visually interesting facades.
- » By combining different cover caps for horizontal and vertical applications, a wide range of external features is possible.
- » Several designer mullions are available for internal design features.
- » Mullions and transoms can be flush internally or can be stepped to emphasise the vertical element and complement the total building design.
- » Several situations such as 90° angle mullions or variable angles have been designed with a minimal use of material allowing slim sightlines.
- » By using the various designer mullions / transoms, in combination with the extensive colour range, the different options are practically unlimited.



Elegance 52 HL is a specific solution when horizontal lining or emphasis is required. The system is based on the Elegance 52 ST basic structure and creates a horizontally continuous effect by changing the vertical cover caps for a hidden profile sealed by a gasket. The hidden profile still allows the tight sealing of the glass against the structure, the gasket masks the vertical detail putting more emphasis on the horizontal cover cap. The horizontal cover caps can be chosen out of a wide range of profiles to integrate in the total building design.

Elegance 52 HL is a project specific variant, consult Sapa Building Systems Ltd for details of availability.

Elegance 52 HL

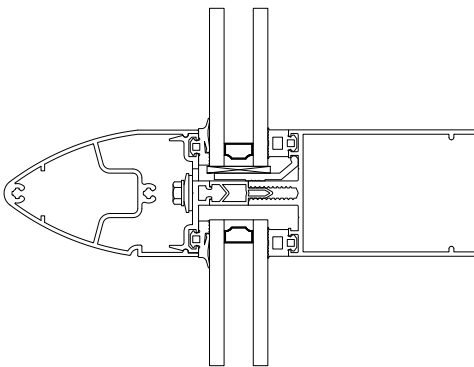
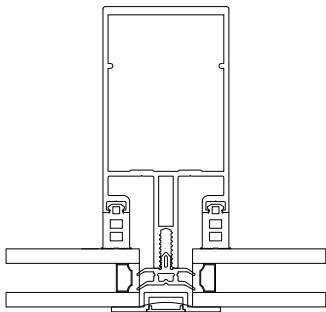
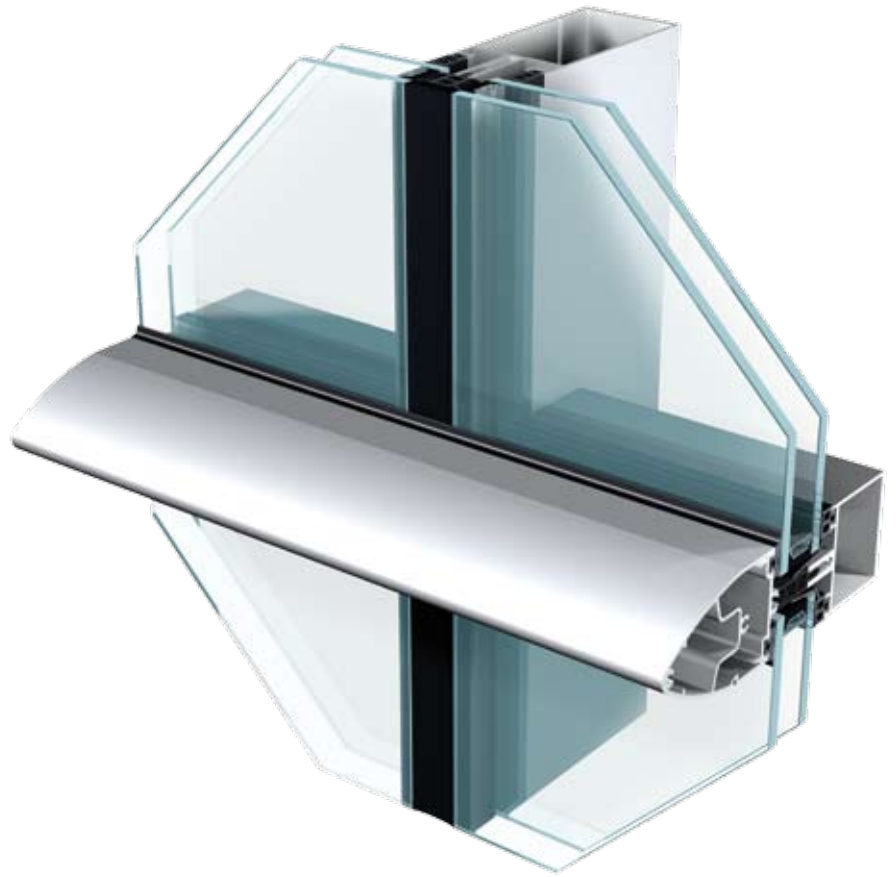





Elegance 52 IN

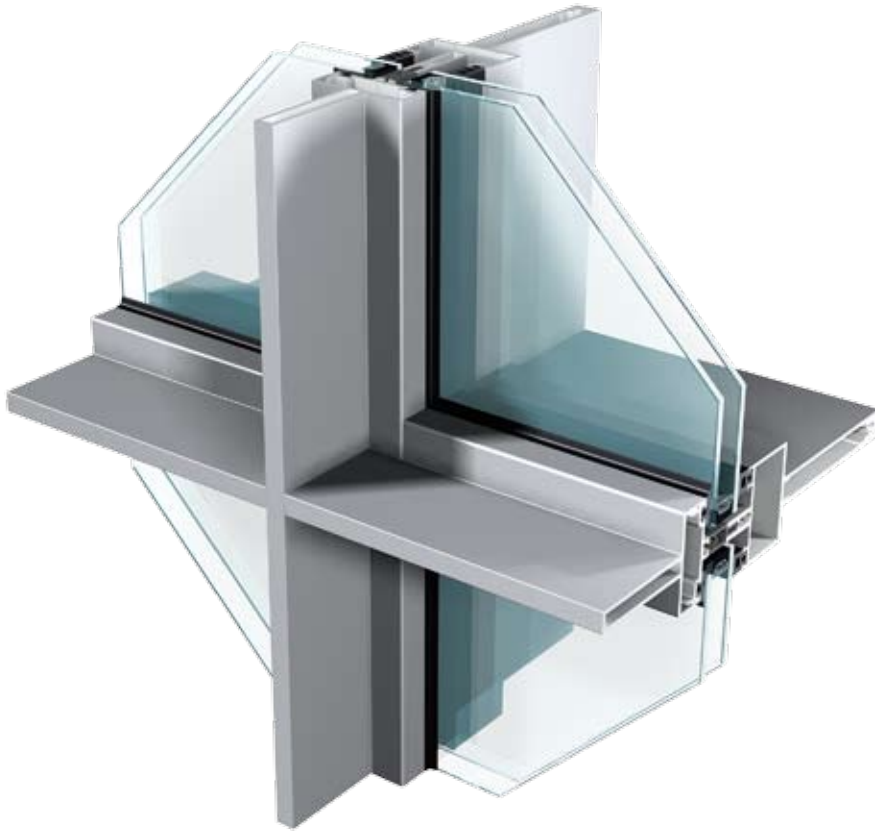

Elegance 52 IN is based on the same Elegance 52 ST principles of drainage, coupling, fabrication and thermal insulation but uses a special range of mullions and transoms to create a slim interior design effect. The resulting anchoring and dilatation solutions have been included.

Where the Elegance 52 ST uses tubular profiles, the Elegance 52 profiles have an I or T shape. At the outside, the system accepts the wide range of pressure plates and cover caps which are used in the standard stick system.

Elegance 52 IN is a project specific variant, consult Sapa Building Systems Ltd for details of availability.

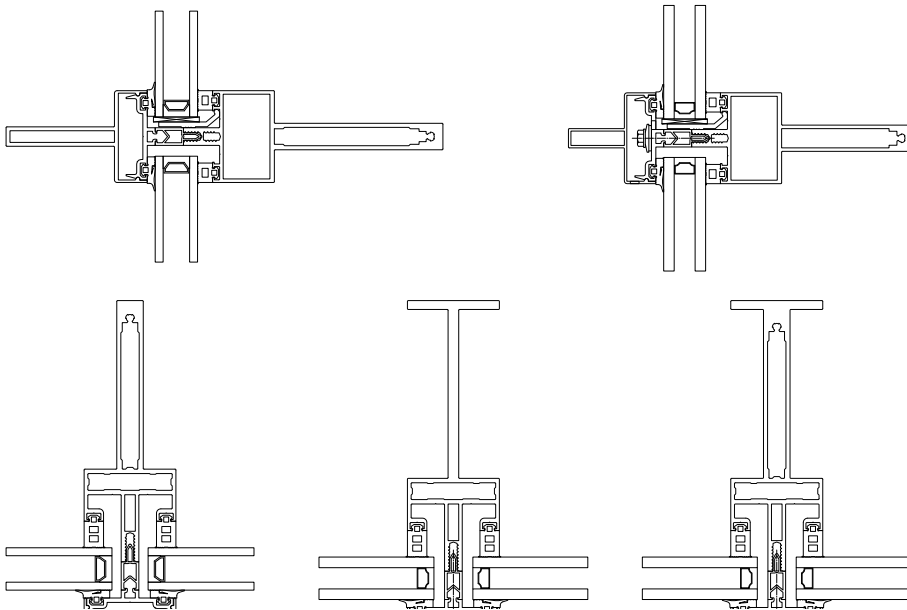

Curtain walls don't only have to be strong and with a slim sightline, they also need to be fire-resistant. The Elegance 52 FR shows that all these properties are possible within the same system. The fire-resistant Elegance 52 FR is used for maximum security for vertical facades and offers state-of-the-art protection against fire and smoke.

Elegance 52FR is a project specific variant with additional and enhanced components. Consult Sapa Building Systems Ltd for details of performance and availability.

Test Standards
EN 1364-3: 2007
EN1363-1: 2000
EN1363-2: 2000

Elegance 52 FR

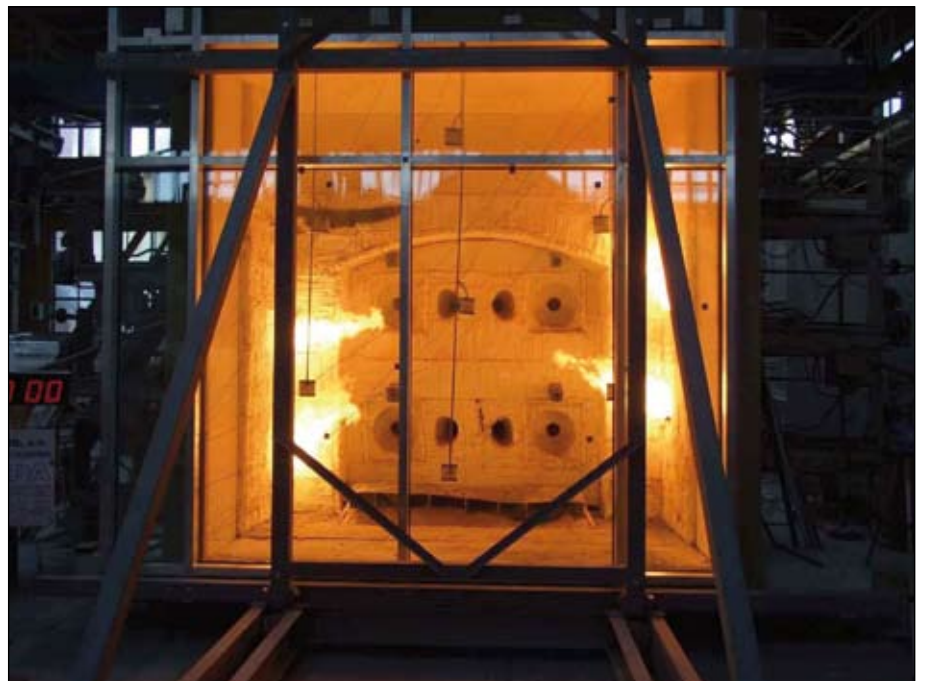
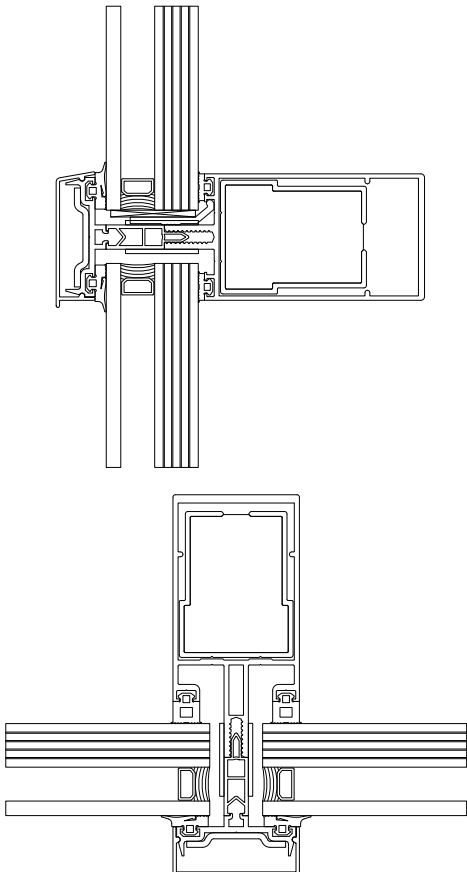

Elegance 52 burglary resistant (class 2)

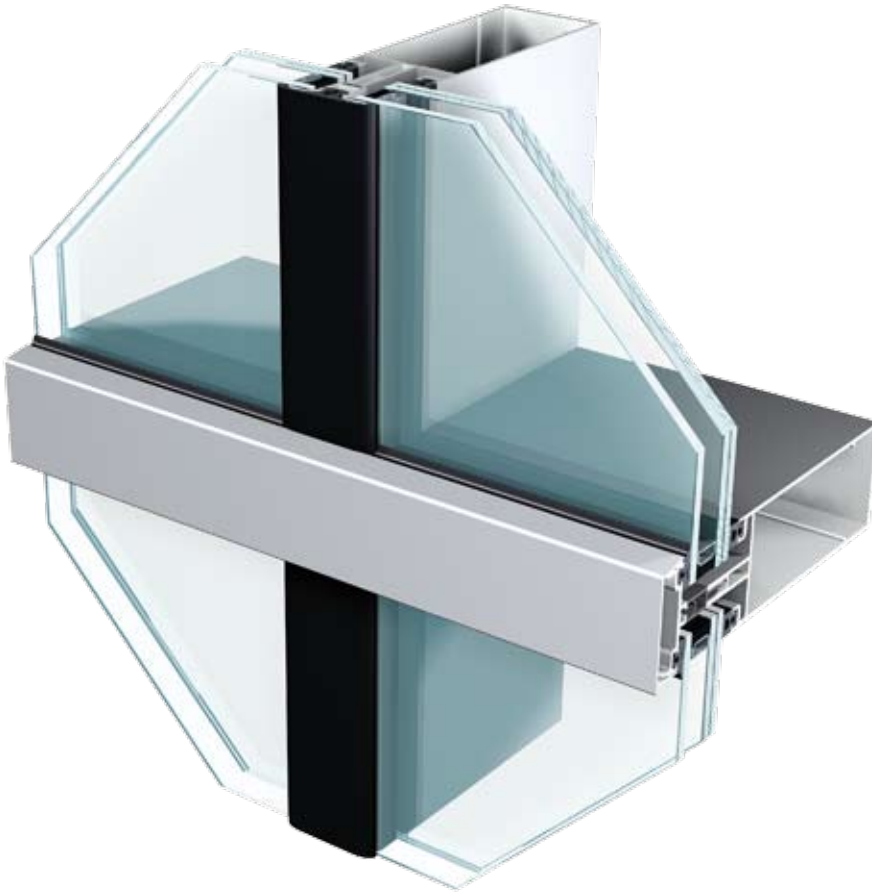

The Elegance 52 burglary resistant (class2) offers an efficient protection against break-in. The special fastenings prevent unauthorized removal of the glazing. The external design is not impaired. And the creative freedom is maintained through custom shapes and colour options.

The Elegance 52 burglary resistant curtain wall means a comprehensively tested security performance.

Elegance 52 Burglary Resistant is a project specific variant, consult Sapa Building Systems Ltd for details of availability.

Tested according standard prEN 1627 - 1630.

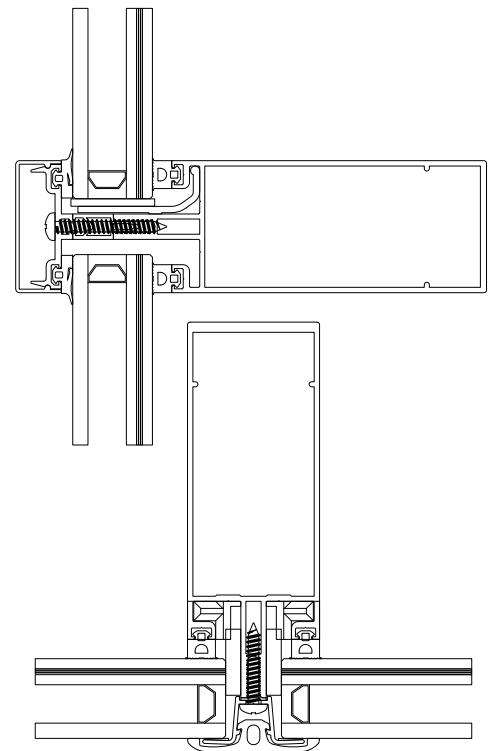

Elegance 52 offers solutions for vertical, slope and roof applications with curtain wall performance.

Elegance 52 roof applications

- » Provides passive solar value
- » Multiple glazing options
- » High performance
- » Positive drainage system

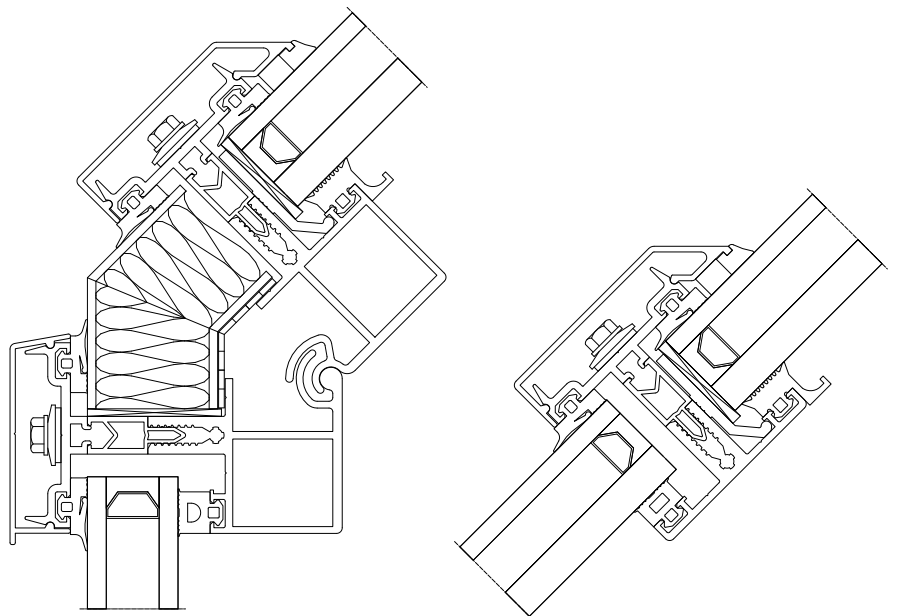
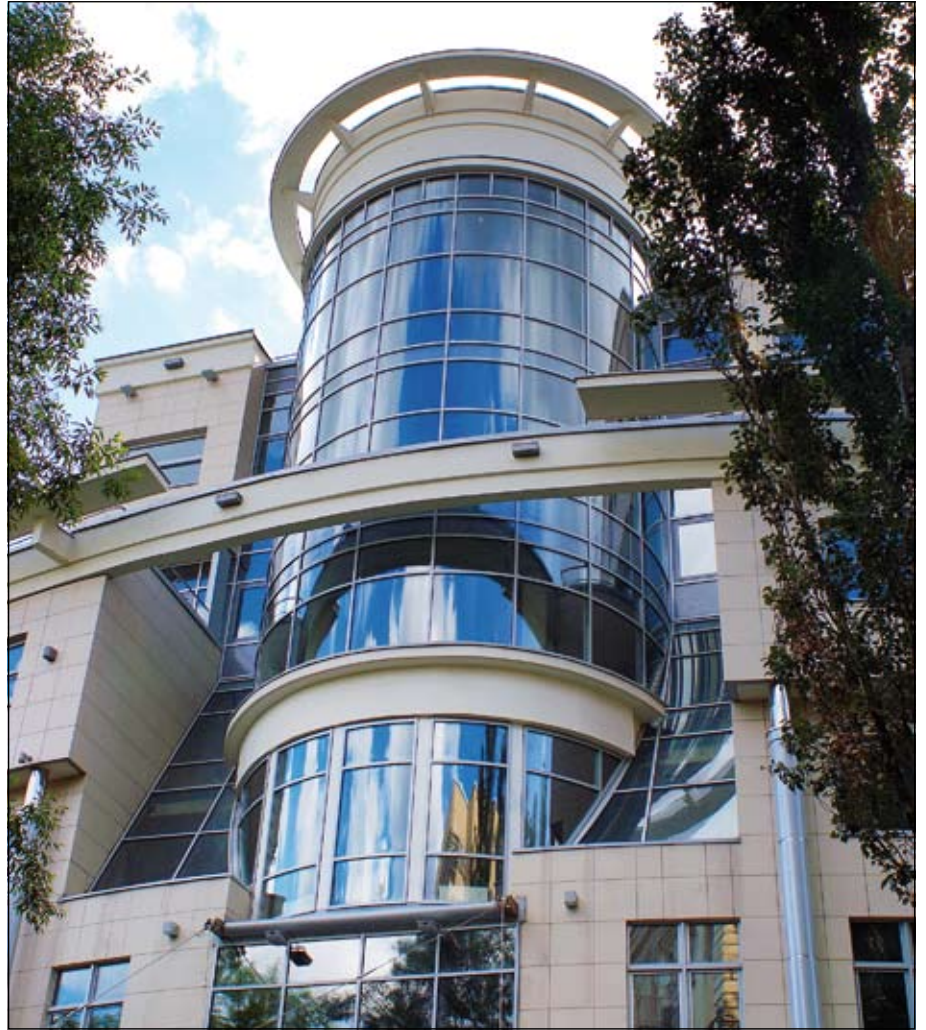

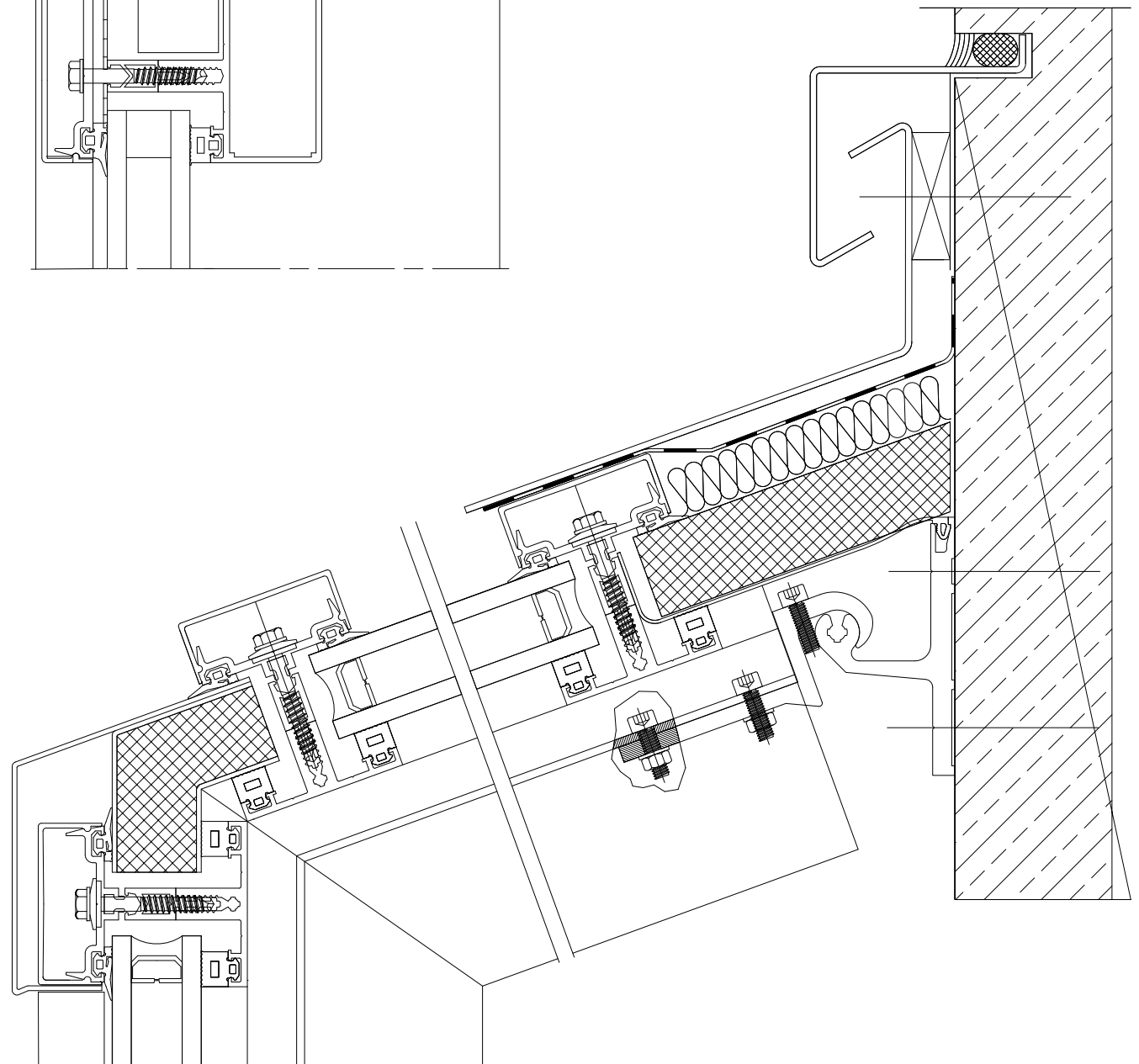
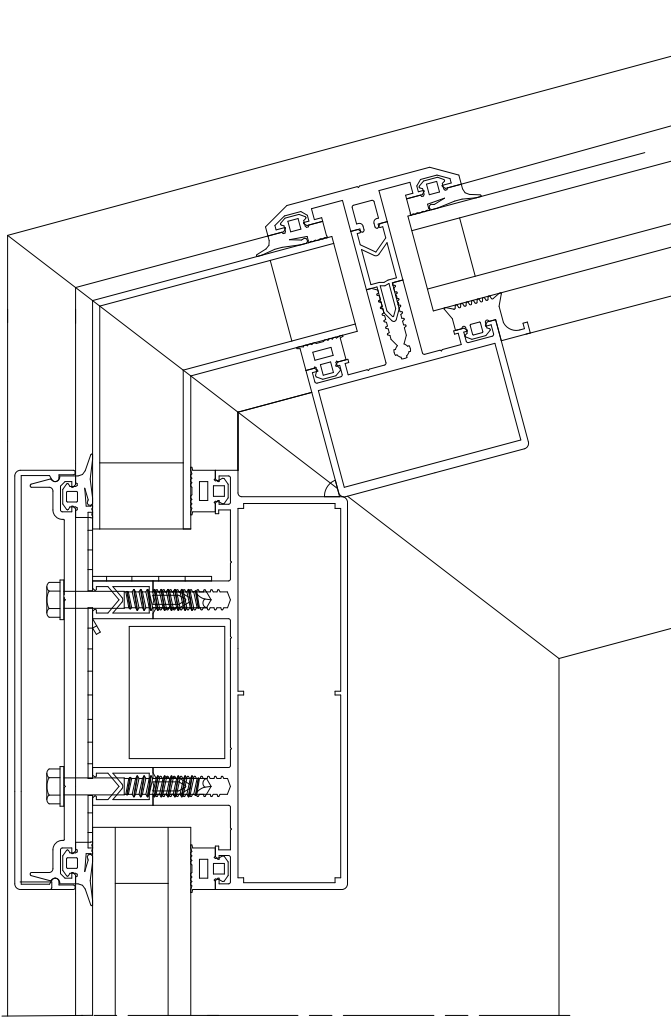

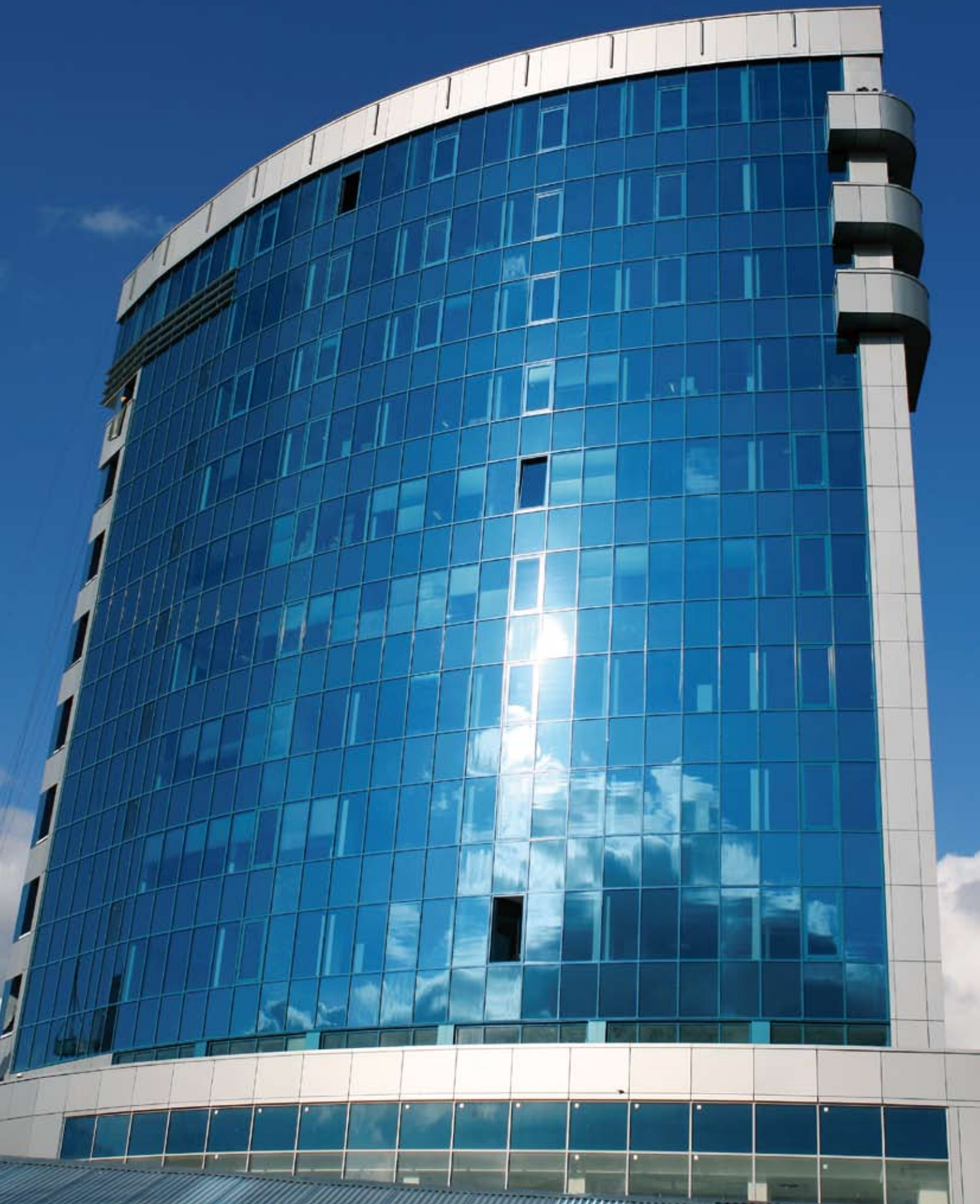

Elegance 52 SI



The Elegance 52 SI (Super Insulation) meets the highest standards in thermal insulation using innovative insulation technology. This highly thermally insulated facade system ensures compliance with the current energy-saving standards and initiatives.

- » Modular system with different insulators.
- » High thermal performance by adding only one component.
- » High level of acoustic insulation.
- » The high thermal performance level improves the overall building insulation, leading to a lower total energy consumption and improving the building's environmental profile.

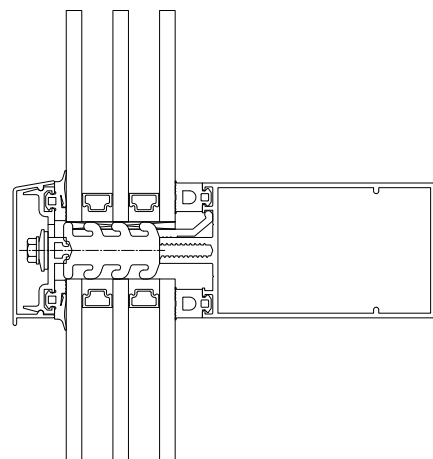
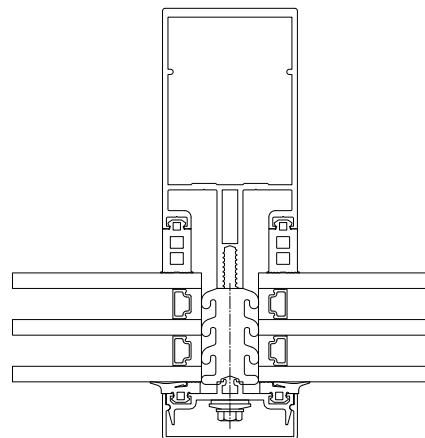

$U_{cw} = 0,88 \text{ W/m}^2\text{K}$

(with $U_g = 0,7 \text{ W/m}^2\text{K}$, element size 1400 x 1600 mm)

Elegance 52 SGV is an outward opening window system, specifically designed to create a vent with a minimal visual aspect to be integrated into the Elegance 52 ST and Elegance HL. The vents can hardly be recognised from the fixed panels.

- » The Elegance 52 SGV is concealed structurally glazed top-hung casement.
- » The double glazing has a stepped edge and is structurally bonded to the vent frame.
- » Gaskets are available for 24 and 28 mm DGU's.
- » Drainage is transferred back into the curtain wall and can therefore be field or mullion.
- » Flipper and bulb gaskets ensure a perfect weather and acoustic performance.
- » Maximum vent size 1600 x 1500 mm high.

It is possible to integrate all standard window and door systems in the Elegance 52 ST and HL by using special outer frame profiles or adaptor profiles.

Elegance 52 SG Vent

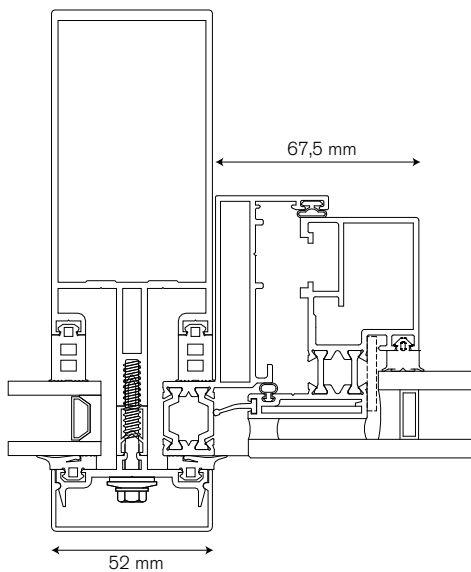
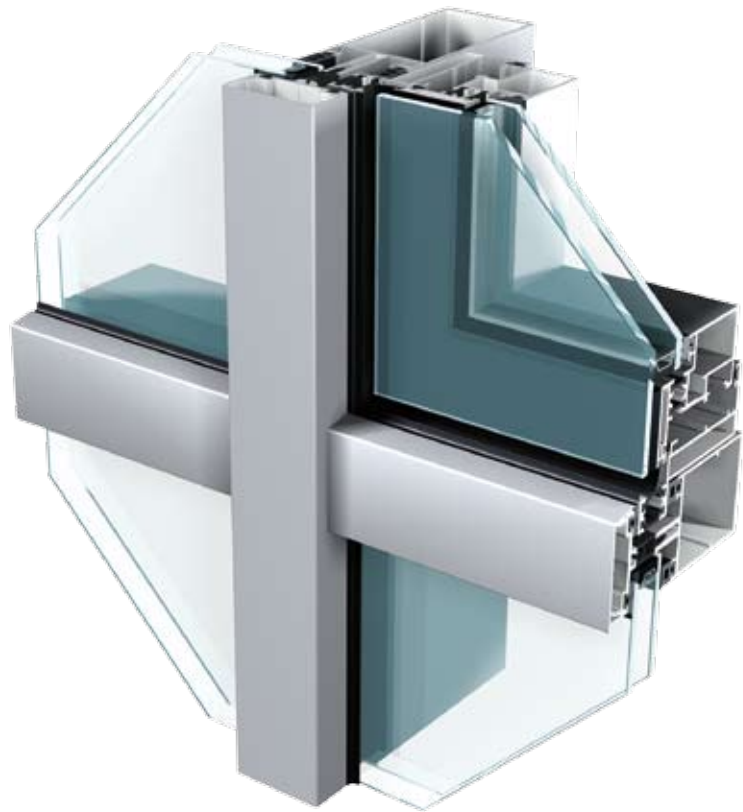



جوان



Elegance 52 SX

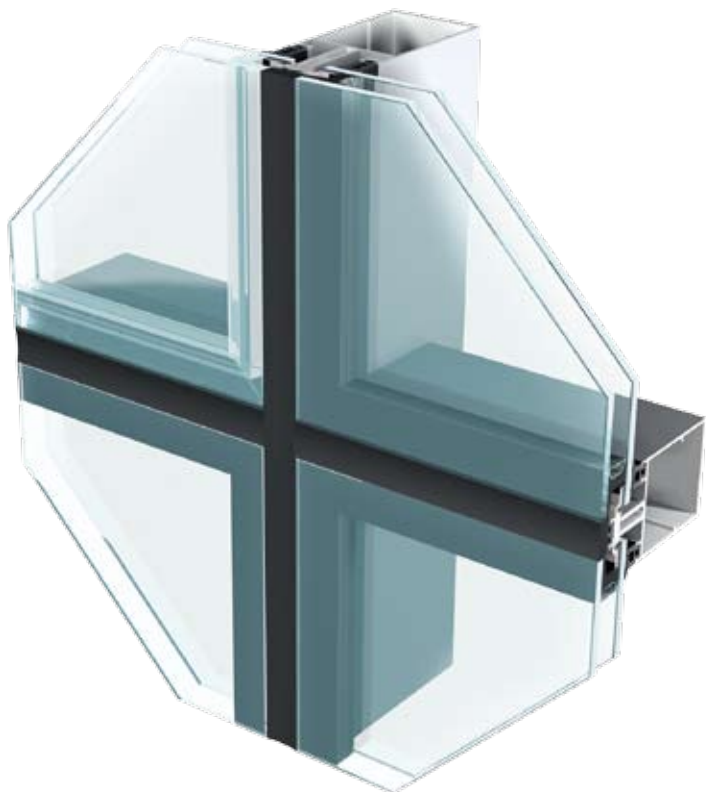

Elegance 52 SX is a structurally clamped aluminium curtain wall system where the glass is retained directly towards the standard structure of Elegance 52 ST with the use of concealed pressure plates. The retained intercalary profile between the double glazed panes provides the area to insert the pressure plates which are directly screwed in the central groove of the mullions and transoms.

This solution provides an economic alternative for the traditional structural glazed curtain walls.

Elegance 52 SX is an alternative to traditional structural glazed systems as it also creates a flush surface appearance.

Elegance 52 SX is a project specific variant, consult Sapa Building System Ltd. for details of availability.

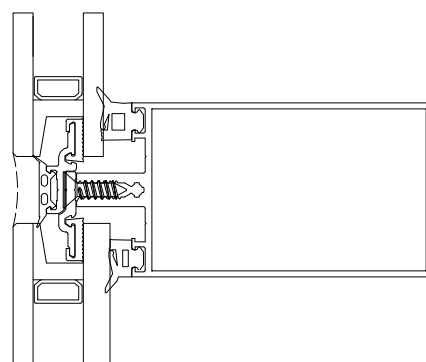
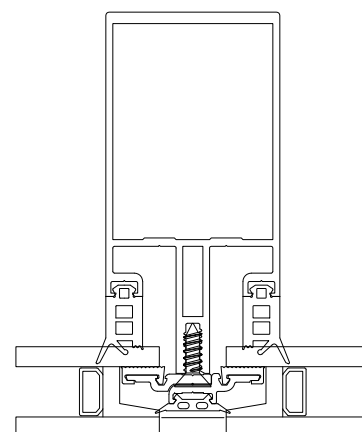

Elegance 52 SG is a structurally glazed curtain wall system using the basic substructure of Elegance 52 and offering a solution for combinations of fixed or opening panels in both straight or faceted applications. The structurally glazed curtain wall offers a minimal sightline without having a visual difference between fixed and opening panels.

Elegance 52 SG

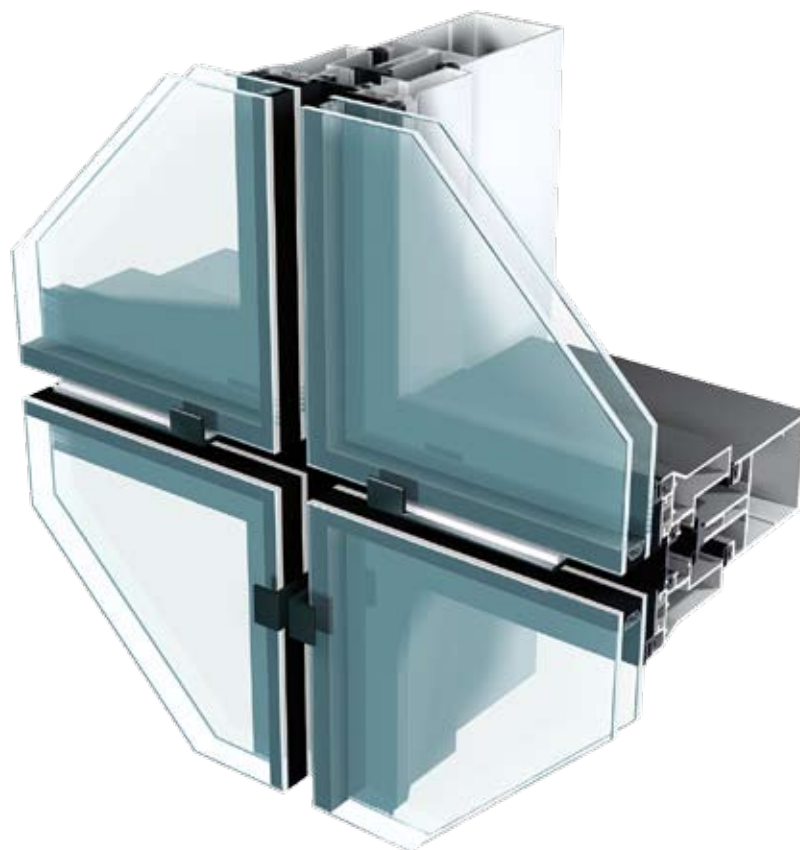

System features

- » The use of a structurally glazed curtain wall avoids the use of cover caps resulting in a flush surface with minimal sightlines.
- » The Elegance 52 SG can accept glazing of 24 to 26 mm.
- » The maximum dimension of a panel is 1500 x 870 mm (height x width).
- » Elegance SG can be used with the SG Vent integrated outward opening window system that does not show a visual difference with the identical fixed panels.
- » Besides glazed panels, it is also possible to use other types of panels.
- » Several gaskets in EPDM offer maximum weather and acoustic performance.
- » Safety clips ensure total security.
- » The wide range of mullion profiles offers an answer to both inertia and design requirements. Mullion and transom profiles can be flush or stepped on the inside.

Fabrication

- » The transoms and mullions are mullion-mullion connected. A cut-out mullion version is available when the transom requires extra support. System-designed connectors make an easy installation.
- » The glass is structurally bonded to an anodised profile in the vent, bonding of the glass to the profile is carried out by specialised, certified companies.
- » Vent profiles are assembled using crimped or eccentric cleats.
- » After assembly of the basic mullion structure, the different panels are positioned and tightened by use of connectors on all sides. It is possible to dismantle the panels if replacement is necessary.

Dimensions

| | |
|----------------------|-------------------------------|
| Sightline inside | 52 mm |
| Sightline outside | 19 mm |
| Mullion depth | 41 - 273 mm |
| inertia (lxx: wind) | 9,57 - 923,84 cm ⁴ |
| Transom depth | 36 - 167 mm |
| inertia (lxx: wind) | 4,15 - 308,02 cm ⁴ |
| inertia (lyy: glass) | 7,29 - 43,74 cm ⁴ |

Glazing

| | |
|------------------|--------------------|
| Infill thickness | 24 - 28 mm |
| Glazing method | structural glazing |

Performances

| | | |
|------------------|---------|------------|
| Thermal break | 14,8 mm | |
| Air permeability | 600 Pa | XP P28-004 |
| Water tightness | 600 Pa | XP P28-004 |
| Wind resistance | 1200 Pa | XP P28-004 |

This information is an indication of potential performance with specific components. For more information, please consult Sapa Building System Ltd for details of availability.

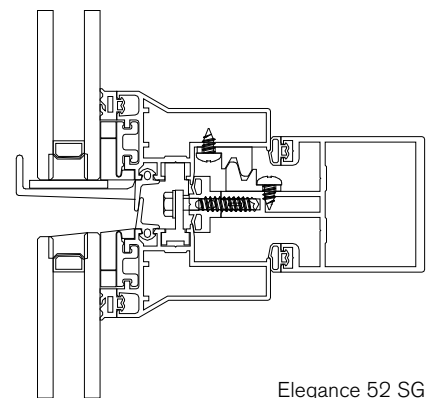

Elegance 52 SG



Elegance 52 GF



Elegance 52 GF is a curtain wall system based on the structure of the Elegance 52 SG using a glazing bead instead of structurally glazing the glass to the panel. The design team developed this solution to offer a version where the glass is held in position with aluminium as in a picture frame. This approach allows each panel to be independent but still be integrated in the full curtain wall.

System features

- » Solutions for both fixed panels as outward opening panels are available.
- » Two designs of glazing beads were developed.
- » Glazing of 20 to 30 mm.
- » Max panel size of 1500 x 900 mm (height x width).
- » The panels are thermally broken, so improving the total energy performance of the building.
- » Panels are completely assembled in the workshop and positioned on to the locating lugs on the structure.

Elegance 52 GF is a project specific variant. Consult Sapa Building Systems Ltd for details of availability.

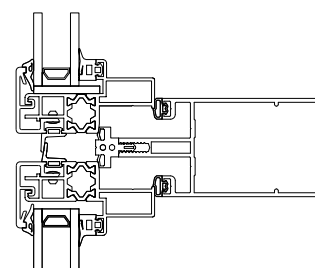
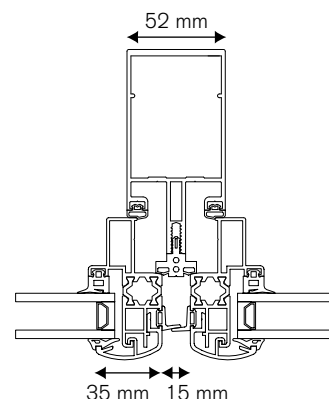

Performances

| | | |
|------------------|--------|----------|
| Air permeability | A2 | EN 12152 |
| Water tightness | R5 | EN 12154 |
| Wind resistance | 800 Pa | EN 13116 |

This information is only an indication of potential performance with specific components. For more information, please consult Sapa Building System Ltd.





PRIME HOSPITAL
مستشفى الاماين

مركز كهربائي



Elegance 52 Sun Control

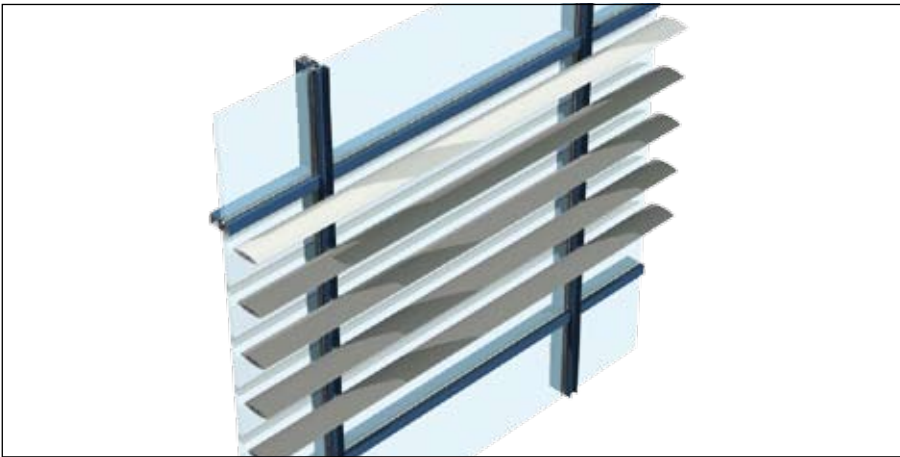
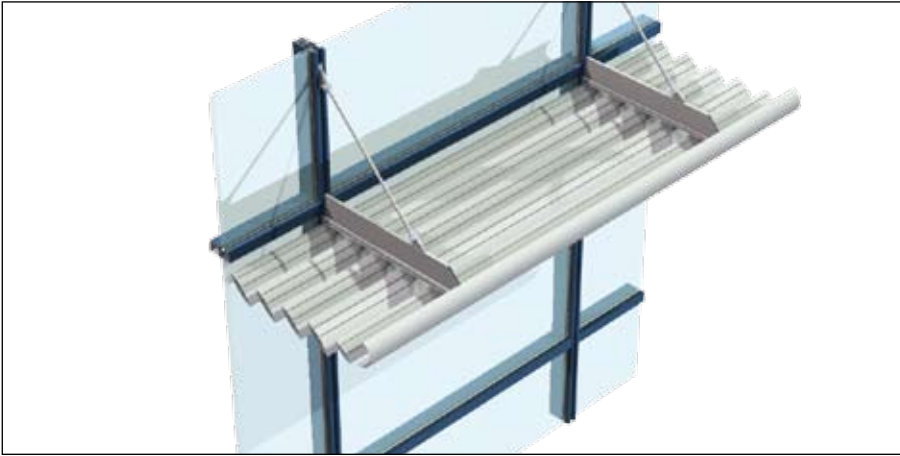

The Solar control range has been developed to compliment Elegance 52 curtain walling and meet the ever increasing energy demands put on the building facade.

Sapa's in-house technical support can provide you with critical, specialist advice concerning the correct application of products across a variety of project types including maintenance and safety.

Eco Clip system

has been developed to provide maximum shading to a facade, both in terms of area coverage and configuration options, whilst using simple profiles that are lightweight and inherently economic.

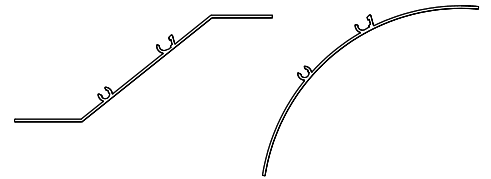

Aero Clip system

has been developed to provide suited solutions for all applications with an emphasis on eye catching design.

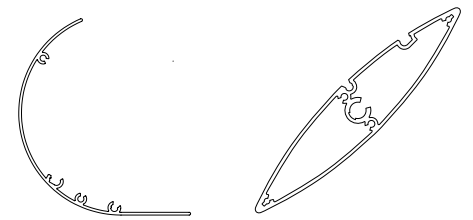

Side-arm system

is a range of blade profiles that can be used to create any shading configuration.

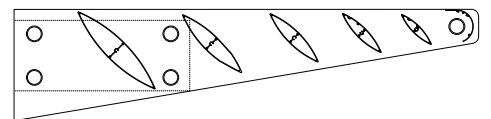

Building Integrated Photovoltaics

As part of the Orkla group, Sapa Building System has all the steps along the value chain of the photovoltaic industry in its own hands. From silicium, through cell and module manufacturing, Sapa Building System provides the complete photovoltaic system for the building envelope.

This includes:

- » project consulting
- » engineering and design
- » complete PV and aluminium product range
- » fabrication and installation network
- » after sales services

Our global presence together with our local network ensure efficient project management close to our customers, in all geographical areas.

Moreover, Sapa is able to implement these Building Integrated Photovoltaics in most of its market leading product groups such as solar shading, curtain walling, glazed roofs, conservatories and windows.

What are Building Integrated Photovoltaics?







While standard PV solutions are often used in residential or solar-farm applications, BIPV provides the architect with completely new possibilities to incorporate solar technology into buildings. PV systems and architecture can now be combined into one harmonious mixture of design, ecology and economy.

Our building integrated photovoltaic modules create a world of possibilities. The wide variety of elegant forms, colours and optical structures of cells, glass and profiles enables creativity and a modern approach to architectural design. It allows specifiers to deliver an energy-efficient, innovative and prestigious project and to set new architectural standards for the future by combining elegance with functionality. PV modules can be incorporated into the building vertically, horizontally or at an angle.

The modules can be tailor-made in accordance with dimensions and customer wishes. A selection of cells and positioning can be adapted according to project design specifics: Transparency, Light control, Module design, Shading, Dimension.



PV cell types and their efficiency

| | dimensions | efficiency | W _{peak} /m ² | W _{peak} /cell |
|---|--------------------|------------|-----------------------------------|-------------------------|
|  Polycrystalline | 156x156 125x125 | 16% | 120 | 1.46 - 3.85 |
|  Monocrystalline | 156x156 125x125 | 18% | 130 | 2.60 - 4.02 |
|  Monocrystalline - High efficient | 125x125 | 22% | 155 | 2.90 - 3.11 |
|  Monocrystalline - semitransparent | 125x125 | 17% | 105 | 1.90 - 2.20 |
|  aSi (Amorphous Silicone) Thin film | 576x976 | 5% | 50 | 32 |
|  aSi Thin film 10% or 20% opacity | 576x976 | 4% | 40-45 | 27 |



A turn key solution for your entire project

Supported by Sapa Building System's extensive expertise and know-how, we provide a complete package with a wide range of services: we investigate which subsidy regulations apply to the project and ensure that national building regulations are met in every detail. Sapa Building System supports with design and engineering for utility connections, cabling plans, electronic, static and thermal calculations. For the installation, our extensive network of experienced installers and builders provides full assistance. For the delivery of BIPV components we cooperate with prominent partners in the building industry.

At Sapa Solar, we drive the entire design process by using our technical expertise and experience: from the very first dialogue with the client, through conceptual drawings, the development of high quality photovoltaic systems that are easy to manufacture to install.

Support offer

- » Engineering study, curtain walling structure, static calculation, design, drawings
- » Photovoltaic study, module proposal, output calculation, electrical data, investment calculation
- » Project budget envelope, timetable estimation, qualified installer recommendation

BIPV project installation

- » Supply of all hardware, profiles, modules and electrics
- » Engineering, installation support, site management, administrative assistance
- » Qualified installer network combining expertise in facade and electronics

Possible combinations cell-type and cell distances

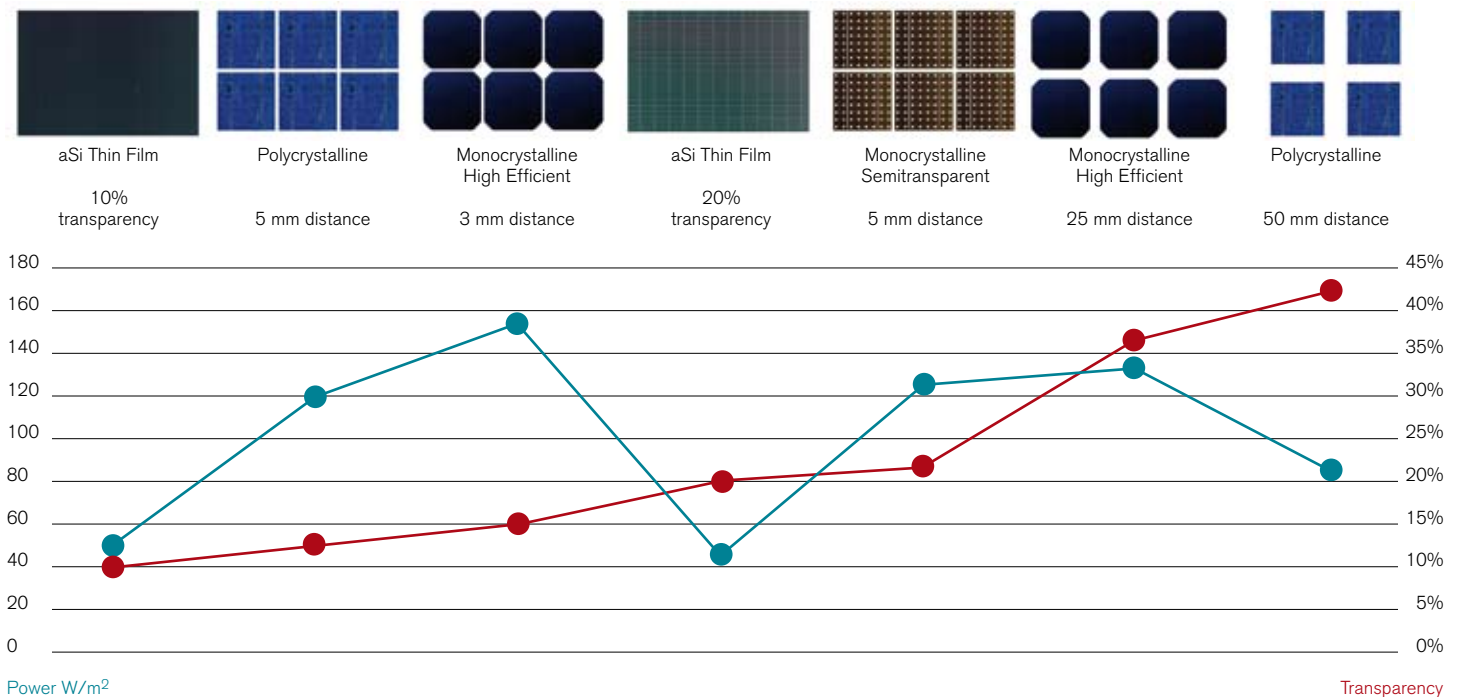

Sapa Building System, is one of the largest suppliers of aluminium building systems in Europe and is part of the Swedish group Sapa. The core business is the development and distribution of aluminium profile systems. Sapa Building System aims for well-developed systems and project solutions offering a tangible added value to fabricators, architects, investors and home-owners.

Windows and Doors

Curtain Walls

Conservatories

BIPV

Sapa Building System Ltd

Postal address **Alexandra Way, Aschchurch, Tewkesbury, Gloucestershire, GL20 8NB**

Tel. **01684 853500**

E-mail info@sapabuildingsystem.co.uk Website www.sapabuildingsystem.co.uk

sapa: